

This Page Is Inserted by IFW Operations
and is not a part of the Official Record

BEST AVAILABLE IMAGES

Defective images within this document are accurate representations of the original documents submitted by the applicant.

Defects in the images may include (but are not limited to):

- BLACK BORDERS
- TEXT CUT OFF AT TOP, BOTTOM OR SIDES
- FADED TEXT
- ILLEGIBLE TEXT
- SKEWED/SLANTED IMAGES
- COLORED PHOTOS
- BLACK OR VERY BLACK AND WHITE DARK PHOTOS
- GRAY SCALE DOCUMENTS

IMAGES ARE BEST AVAILABLE COPY.

**As rescanning documents *will not* correct images,
please do not report the images to the
Image Problem Mailbox.**

THIS PAGE BLANK (USPTO)

(19) World Intellectual Property Organization
International Bureau



(43) International Publication Date
29 March 2001 (29.03.2001)

(10) International Publication Number
PCT
WO 01/21100 A1

(51) International Patent Classification⁷:
A61B 17/22

A61F 2/01,

(74) Agents: HOTCHKISS, Edward, S. et al.; Fredrikson & Byron, P.A., 1100 International Centre, 900 Second Avenue South, Minneapolis, MN 55402 (US).

(21) International Application Number: PCT/US00/25049

(81) Designated States (*national*): AE, AG, AL, AM, AT, AU, AZ, BA, BB, BG, BR, BY, BZ, CA, CH, CN, CR, CU, CZ, DE, DK, DM, DZ, EE, ES, FI, GB, GD, GE, GH, GM, HR, HU, ID, IL, IN, IS, JP, KE, KG, KP, KR, KZ, LC, LK, LR, LS, LT, LU, LV, MA, MD, MG, MK, MN, MW, MX, MZ, NO, NZ, PL, PT, RO, RU, SD, SE, SG, SI, SK, SL, TJ, TM, TR, TT, TZ, UA, UG, US, UZ, VN, YU, ZA, ZW.

(22) International Filing Date:
13 September 2000 (13.09.2000)

(25) Filing Language: English

(26) Publication Language: English

(30) Priority Data:
09/400.159 21 September 1999 (21.09.1999) US

(84) Designated States (*regional*): ARIPO patent (GH, GM, KE, LS, MW, MZ, SD, SL, SZ, TZ, UG, ZW), Eurasian patent (AM, AZ, BY, KG, KZ, MD, RU, TJ, TM), European patent (AT, BE, CH, CY, DE, DK, ES, FI, FR, GB, GR, IE, IT, LU, MC, NL, PT, SE), OAPI patent (BF, BJ, CF, CG, CI, CM, GA, GN, GW, ML, MR, NE, SN, TD, TG).

(71) Applicant (*for all designated States except US*): MICROVENA CORPORATION [US/US]; 1861 Buerkle Road, White Bear Lake, MN 55110 (US).

Published:
— With international search report.

(72) Inventors; and

(75) Inventors/Applicants (*for US only*): KUSLEIKA, Richard, S. [US/US]; 18188 Ullmann Circle, Eden Prairie, MN 55346 (US). FINANDER, Brian, V. [US/US]; 4505 Birch Briar Road, Vadnais Heights, MN 55127 (US).

For two-letter codes and other abbreviations, refer to the "Guidance Notes on Codes and Abbreviations" appearing at the beginning of each regular issue of the PCT Gazette.

(54) Title: TEMPORARY VASCULAR FILTER

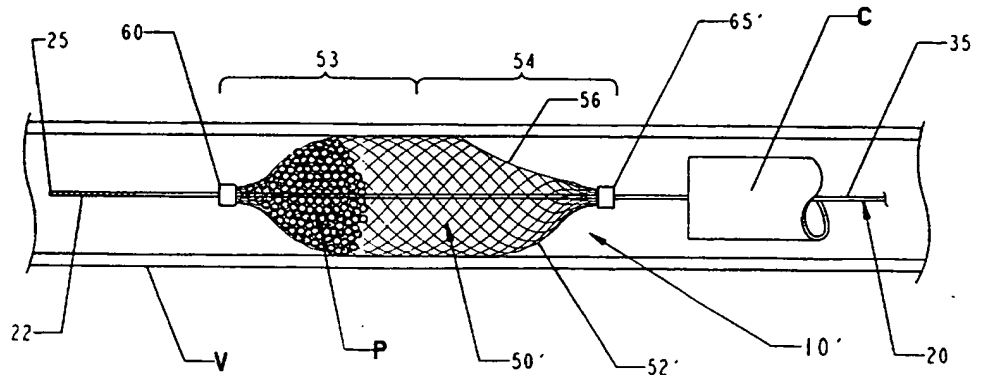

WO 01/21100 A1

(57) Abstract: The present invention provides a method of deploying a medical filter within a channel in a patient's body and filter systems which can be used in such a method. Such a filter may include a radially expandable body (52) having an opening (56) in a proximal length thereof. In one method, the filter is urged along a length of the channel with the filter body in a radially reduced configuration. This body is expanded to substantially fill the lumen of the vessel and orient the opening in the body proximally. Body fluid is permitted to enter the filter body through the proximally oriented opening and pass distally through the distal length of the body so that the distal length of the body filters from the body fluid particulate material entrained therein. The proximal length of the body can be drawn into the retrieval catheter, thereby effectively closing the proximally oriented opening within the catheter to retain the particulate material within the enclosure. In a preferred embodiment, the filter body (52) is formed of a porous, resilient fabric having pores therein and the proximal opening (56) is at least five times the size of such pores.

THIS PAGE BLANK (USPTO)

TEMPORARY VASCULAR FILTER

FIELD OF THE INVENTION

The present invention generally relates to filters for body passageways, and has particular utility in connection with temporary vascular filters.

BACKGROUND OF THE INVENTION

5 Filters can be deployed in channels or vessels in patient's bodies in a variety of medical procedures or in treating certain conditions. For example, rotating burrs are used in removing atheroma from the lumen of patients' blood vessels. These burrs can effectively dislodge the atheroma, but the dislodged
10 material will simply float downstream with the flow of blood through the vessel. Filters can be used to capture such dislodged material before it is allowed to drift too far downstream, possibly occluding blood flow through a more narrow vessel.

Some researchers have proposed various traps or filters for capturing the particulate matter released or created in such procedures. However, most such
15 filters generally have not proven to be exceptionally effective in actual use. These filters tend to be cumbersome to use and accurate deployment is problematic because if they are not properly seated in the vessel they can drift to a more distal site where they are likely to do more harm than good. In addition, these filters are generally capable of only trapping relatively large thrombi and are not effective for
20 removing smaller embolic particles from the blood stream.

The problems with most temporary filters, which are intended to be used only during a particular procedure then retracted with the thrombi trapped therein, are more pronounced. Even if the trap does effectively capture the dislodged material, it has proven to be relatively difficult or complex to retract the trap back
25 into the catheter through which it was delivered without simply dumping the trapped thrombi back into the blood stream, defeating the purpose of the temporary filter device. For this reason, most atherectomy devices and the like tend to aspirate the patient's blood during the procedure to remove the dislodged material entrained therein.

30 One promising filter design which overcomes many of these difficulties is shown in International Publication No. WO 96/01591 (the publication of PCT

International Application No. PCT/US95/08613), the teachings of which are incorporated herein by reference. Generally, this reference teaches a trap which can be used to filter particles from blood or other fluid moving through a body vessel. In one illustrated embodiment, this trap includes a basket 270 which can
5 be deployed and retracted through a catheter or the like, making it particularly suitable for use in minimally invasive procedures such as angioplasty or atherectomy procedures. The fact that this trap is optimally carried on a mandrel 260 further enhances its utility as most common angioplasty balloons and atherectomy devices are used in conjunction with such mandrels. While this trap
10 is very useful and shows great promise in many common procedures, it may be possible to better retain the thrombi collected in the filter during retrieval of the filter.

SUMMARY OF THE INVENTION

The present invention provides a method of deploying a medical filter within
15 a channel in a patient's body and devices which are well suited for use in such procedures. In accordance with one method of the invention, a filter and retrieval catheter are provided. This filter has a radially expandable body having proximal and distal ends and which defines an enclosure. The expandable body has a distal length and a proximal length which includes an opening therein. The
20 retrieval catheter has a lumen with a diameter less than the maximum dimension of the body's expanded configuration. This filter is urged along a length of the channel in the patient's body with the filter body in a radially reduced configuration. The body is radially expanded to its expanded configuration such that it substantially fills the lumen of the vessel and the opening in the body is
25 oriented proximally. Body fluid is permitted to enter the enclosure through this proximally oriented opening and is permitted to pass through the distal length of the body. In so doing, the distal length of the body filters from the body fluid particulate material entrained therein (assuming, of course, that there is any such
30 particulate material of an appropriate size). The proximal length of the body is drawn within the lumen of the catheter, thereby effectively closing the proximally oriented opening within the retrieval sheath to retain said particulate material within the enclosure.

Further refinements of this method are envisioned. For example, in one embodiment, the filter has a narrow proximal end which is smaller than the lumen of the catheter. In drawing the proximal length of the filter within the catheter, this narrow proximal end may be introduced into the distal end of the catheter's lumen.

5 The filter may then be retracted until the internal surface of the catheter engages the body of the filter distally of the opening to effectively create a particulate seal therebetween.

As noted above, the present invention also encompasses a device well suited for use in such procedures. In one embodiment, such a device comprises

10 a collapsible filter system including a mandrel and a filter. The mandrel has proximal and distal ends and the filter is carried along the mandrel between these ends. The filter has a radially expandable body having proximal and distal ends of its own. The body is formed of a porous, resilient fabric having pores therein through which a body fluid may pass, but which are small enough to restrict

15 passage of particulate material over a certain, predetermined size entrained in the body fluid. A proximally oriented hole passes through the fabric along a proximal length of the filter's body. This hole is spaced distally of the proximal end of the body and being at least about five times the size of said pores.

BRIEF DESCRIPTION OF THE DRAWINGS

20 Figure 1 is a perspective view of a medical filter in accordance with one embodiment of the present invention;

Figure 2 is a side elevation view of the filter of Figure 1;

Figure 3 is a cross sectional view of the medical filter of claim 1, taken along line 3-3 of Figure 2;

25 Figure 4 is a schematic side view in partial cross section illustrating a filter of an alternative embodiment of the invention in a radially reduced configuration within a catheter;

Figure 5 is a schematic side view illustrating the filter of Figure 4 deployed in a vessel in a patient's body;

Figure 6 is a schematic side view of the filter of Figures 4 and 5 with collected particulate material trapped within the filter;

Figure 7 is a schematic side view of the filter of Figures 4-6 drawn far enough into the catheter to effectively close the proximally oriented opening within the catheter; and

Figure 8 is a schematic side view of the filter of Figures 4-7 withdrawn completely within the lumen of the catheter.

DETAILED DESCRIPTION OF THE PREFERRED EMBODIMENTS

Figures 1-3 illustrate a filter system 10 in accordance with one embodiment of the invention. This filter system can be used in any channel in a patient's body, including blood vessels, the urinary tract or biliary tract and airways. This filter system 10 is optimally designed to be deployed in a patient's vessel in a minimally invasive procedure, such as by introducing the filter system into a blood vessel through a catheter (as described in greater detail below).

The filter system 10 of the invention generally includes a mandrel 20 and a filter 50. Conceptually, the mandrel 20 can be thought of as having a primary function of positioning and controlling the deployment of the filter 50 while the filter can be considered the primary therapeutic or functional element of the system 10.

The mandrel 20 should be fairly flexible to allow the device to be deployed in a curving body passageway without kinking or otherwise inhibiting suitable deployment of the filter 50. While the mandrel can be formed of any material having any dimension suitable for the task for which the filter system 10 is to be employed, in most circumstances, the mandrel 20 will comprise an elongate metal wire. In one particularly preferred embodiment, the mandrel 20 is formed of nitinol, a roughly stoichiometric alloy of nickel and titanium having excellent "superelastic" properties. The use of nitinol in medical guidewires and related applications is well known in the art and need not be discussed in detail here. If so desired, the distal-most length of the mandrel may include a flexible helically wound coil 22 extending thereover. The use of such helical coils to enhance flexibility of the distal tip is well known in the guidewire art.

The mandrel 20 shown in Figures 1-3 has an enlarged diameter stop 40 attached thereto. The stop 40 is spaced proximally from the distal tip 25 of the mandrel 20. Desirably, the stop 40 is spaced proximally of the proximal end of the helical coil 22 of the mandrel. This permits the distal slider 60 of the filter 50 to slide relatively freely and unencumbered along the length of the mandrel distally of the stop.

The stop 40 can be formed of any desired material and can be attached to the mandrel 20 in any desired fashion. The stop should be attached to the mandrel relatively securely, though, as the stop will be used to urge the filter 50 within the lumen of the vessel in which the system 10 is to be deployed. As an example, the stop 40 may comprise a standard radiopaque marker band which has been securely crimped on the mandrel 20 and/or attached to the mandrel using an adhesive or solder. The precise length and shape of the stop 40 is not critical. The drawings illustrate the stop 40 as a relatively short cylindrical body attached about the circumference of the mandrel. However, the stop 40 may have a more bulbous shape and could, in theory, even be formed integrally with the mandrel.

The stop 40 effectively divides the mandrel into distal and proximal lengths. The distal length 30 of the mandrel can be thought of as that length which extends distally from the stop 40 to the distal tip 25 of the mandrel. Likewise, the proximal portion 35 of the mandrel 20 can be thought of as comprising the length of the mandrel extending proximally from the stop 40 to the proximal end of the mandrel.

The filter 50 shown in Figures 1-3 has an elongate, generally tubular body 52 which extends from a distal slider 60 proximally to a proximal slider 65. The body 52 of the filter can be formed of any material suitable for the application at hand. In many applications, e.g., filtering blood within a patient's vasculature, the filter body 52 typically comprises a length of a braided tubular fabric. The use of a tubular braid of nitinol to make medical devices is described in some detail in International Publication No. WO 96/01591, the teachings of which were incorporated above by reference. Briefly speaking though, this process can employ a tubular braid of a fabric comprising two sets of nitinol wires wrapped helically about a mandrel, with one set of wires being wrapped spirally about the mandrel in one direction and the other set being wrapped in the other direction.

This braid is then placed in contact with a molding surface of a molding element which defines the shape of the desired functional element. By heat treating the fabric in contact with the molding surface of the molding element, one can create a functional element having virtually any desired shape.

5 The body 52 of the filter 50 desirably is made of a fairly flexible, resilient material. In particular, the filter 52 desirably has a radially expanded configuration, e.g., the shape shown in Figures 1-3, which the device will tend to resiliently assume in the absence of any countervailing biasing force. A body 52 formed of a nitinol tubular braid which has been heat set into the desired shape
10 should suit this purpose well.

In the filter system 10 shown in Figures 1-3, the body 52 of the filter 50 assumes a generally tubular shape having tapered proximal and distal ends. The maximum outer diameter of the middle length of the body 52 should be sized to substantially fill the lumen of a vessel to ensure that the filter will effectively
15 preclude any emboli (or other particulate material which may be entrained in the patient's bloodstream) from passing around the filter.

The body of the filter includes a distal length 53 and a proximal length 54, each of which tapers from the middle of the body's length to their respective ends. In particular, the distal length 53 tapers distally toward a narrow distal end
20 adjacent the distal slider 60 while the proximal length 54 of the filter body tapers toward its proximal end adjacent the proximal slider 65. The rate of this tapering can be varied as desired. While Figures 1-3 illustrate a fairly gradual taper, the change in diameter may be more abrupt. The filter body 52 of Figures 1-3 is also fairly symmetrical, with the tapers of the proximal and distal lengths being about
25 the same. In some circumstances it may be advantageous to have the two lengths taper differently, e.g. where the proximal length tapers more gradually while the distal length changes diameter more abruptly.

The proximal length 54 of the filter body has at least one proximally oriented opening 56 therein. This opening passes through the flexible, resilient
30 fabric of which the body 52 desirably is formed. The fabric has pores therein which allow fluids to pass therethrough, but the pores are small enough to prevent passage of particles larger than a predetermined size. If the body is formed of a metallic tubular braid as mentioned above, the maximum sizes of these pores can

be controlled by adjusting the number of wires in the braid and the pick and pitch of the braid. For example, if the filter 50 is to be employed as a vascular filter, a pore size of 20-1500 microns is desirable. If such a filter body has a maximum diameter of about 4 mm, it may be formed of 48 wires each having a diameter of
5 about 0.002 inches (about 50 microns) and a pick rate of about 90 per inch (about 35 per centimer).

The size of the proximally oriented opening 56 should be sufficient to permit body fluid with particulate material entrained therein to enter the enclosure within the body 52 of the filter. At a minimum, it is expected that the opening will
10 be at least five times the maximum pore size of the fabric of which the body is formed, with an opening of at least ten times the maximum pore size being preferred.

The opening 56 can be formed in any suitable fashion. If the filter is formed from a preformed flat sheet of fabric wrapped into the desired shape, the opening
15 can be cut through the fabric before the fabric is shaped into the filter body. If the body 52 is formed of a tubular metallic braid, it may instead be cut through the fabric after the braid is heat set in the desired shape.

In one particularly preferred method of forming the filter (which method comprises another embodiment of the invention), a tubular metal braid is
20 provided. The distal and proximal sliders 60, 65 are attached to the braid a suitable distance from one another. The braid is trimmed at the distal end of the distal slider 60 and at the proximal end of the proximal slider 65. A forming mandrel (not shown) is passed between the wire strands of the braid and positioned within the tubular braid.

The forming mandrel has an external molding surface which generally coincides with the desired shape of the filter body. The forming mandrel may have a larger diameter than the inner diameter of the tubular braid and the braid may be drawn down against the forming mandrel by applying axial tension to the braid. This structure may be heated at an elevated temperature to heat-set the
25 filter body 52 in this shape and the forming mandrel may be removed.

The forming mandrel includes a proximal projection having a periphery the size and shape of the desired proximal opening 56. This projection extends through the wire mesh of the tubular braid during heat treatment, forcing the wire
30

strands to extend about the periphery of the projection. As a consequence of the heat treatment, when the forming mandrel is removed, the wires will retain the proximal opening without requiring cutting the fabric.

In Figures 1-3, the filter 50 is shown as having a single opening 56 extending over only one side of the proximal length 54 of the filter body (i.e., above the mandrel 20 in Figure 2). To increase the percentage of body fluid which passes into the enclosure of the filter body, the number of openings or the shape of the opening(s) can be adjusted to maximize the cross sectional area of the vessel covered by the openings. For example, a plurality of openings can be spaced equiangularly about the proximal length 54, such as three openings arranged about 120 degrees from one another.

The opening 56 in Figures 1-3 is generally elliptical with a major axis extending generally in a plane which contains the axis of the mandrel 20. If one were to increase coverage of the opening 56 by adjusting its shape, the strength of the filter and its connection to the proximal slider 65 should not be compromised. One way to accomplish this is to offset the filter 50 with respect to the mandrel 20. In Figures 1-3, the body 52 of the filter is generally symmetrical about a central longitudinal axis and this axis generally coincides with the axis of the mandrel. One could instead make the filter asymmetrical, with the axis of the mandrel 20 spaced radially outwardly from the central axis of the body 52. In such a design, the mandrel could extend adjacent to one side of the body and the opposite side of the body would extend farther from the mandrel. By positioning the opening 56 on the larger side of the body, the opening can be made larger and cover more of the cross sectional area of the vessel in which the filter is deployed.

While the opening 56 can extend up to or even into the proximal slider 65, in a preferred embodiment the opening 56 is spaced distally from the slider 65 and the proximal end of the body 52. This will enable a more secure connection between the slider 65 and the body. The distal end of the opening desirably terminates proximally of the location where the filter body has its maximum diameter. This will minimize the chance that body fluid could slip between the filter and the wall of the vessel in which the filter is deployed. This will also provide a more effective seal between the filter body 52 and the catheter in which

it is retrieved. (Such retrieval is discussed below in connection with Figures 7 and 8.)

The filter 50 is attached to or carried by the mandrel 20 by means of a proximal slider 65 attached to the body 52 adjacent its proximal end and a distal slider 60 attached adjacent the distal end of the body 52. The distal slider 60 should be free to slide along at least a proximal portion of the distal length 30 of the mandrel while the proximal slider 65 should be free to slide along at least a distal portion of the proximal length 35 of the mandrel. In use, the stop 40 of the mandrel effectively defines a limit on the range of motion of these sliders 60, 65.

While each of the sliders 60, 65 should be slidable along its respective length of the mandrel, the sliders can take any desired shape. In the illustrated embodiments, each slider comprises a relatively thin ring which is carried about the mandrel. The thin ring can be attached to the body 52 in any desired fashion, such as by crimping or swaging the fabric of the body between two layers of the ring or soldering, welding or otherwise adhering the fabric to the ring.

The stop 40 of the mandrel is positioned within the body 52 of the filter and is not exerting any biasing force on either of the sliders 60, 65. In this configuration, the mandrel 20 can be moved proximally and distally with respect to the filter 50 without substantially affecting the shape or position of the filter. The limits of this range of free movement of the mandrel with respect to the filter are generally defined by the relationship between the stop 40 and the sliders 60, 65. In particular, the mandrel can be moved from a distal position wherein the stop 40 abuts but does not exert any force on the distal slider 60 and a proximal position wherein the stop 40 abuts, but does not exert any significant force on, the proximal slider 65. This allows the filter 50 (or any other functional element which is carried by the mandrel) to be fairly precisely positioned within a patient's vessel and retain that position even if the guidewire is moved slightly during use. This can be advantageous in circumstances where other devices are exchanged over the guidewire (e.g., during angioplasty and atherectomy procedures).

The inner diameter of the generally annular collars defining the sliders 60, 65 is desirably larger than the outer diameter of the mandrel, but should be smaller than the outer diameter of the stop 40. In this fashion, the stop serves as an effective limit on proximal movement of the distal slider 60 and distal

movement of the proximal slider 65. Apart from this relationship with the slider 40 and the fact that both sliders are indirectly linked to one another by the body 52 of the filter, the proximal and distal sliders are slidable along the mandrel essentially independently of one another.

5 When the mandrel 20 is urged distally (to the left in Figures 2 and 3) against the distal slider 60, the stop will exert a distal biasing force against the distal end of the body 52 of the filter. In theory, if the filter were used in a frictionless environment, the filter would travel with the mandrel without any appreciable alteration in the shape of the body 52. In most clinical applications,
10 though, this is not the case. Instead, there is typically some force restraining completely free movement of the filter within the channel of the patient's body. Typically (and as suggested in Figures 5 and 6, for example), the body 52 of the filter will resiliently expand into physical contact with the interior surface of the vessel within which it is deployed. This contact with the vessel wall will tend to
15 hold the filter 50 in place as the stop of the mandrel slides proximally and distally between the two sliders 60, 65. When the mandrel is urged distally until it exerts a distal force against the distal slider 60, this force will tend to axially elongate the body 52.

 Resilient tubular braids tend to assume a radially reduced profile upon axial
20 elongation. (This property and some of its implications are discussed in International Publication No. WO 96/01591, mentioned previously.) As a consequence, when the mandrel 20 is urged distally to push distally against the distal slider 60, this distal force acts against the restorative force of the resilient braid, which would otherwise bias the braid into its expanded configuration
25 (Figures 1-3). By overcoming this restorative force with a countervailing distal force, the body 52 will tend to both axially elongate and assume a radially reduced profile. This, in turn, reduces the force with which the body engages the wall of the vessel or catheter in which the filter is positioned and reduces friction between the filter 50 and the vessel or catheter. Hence, urging the mandrel distally to
30 move the filter 50 distally will, at the same time, reduce friction between the filter and the vessel wall to further facilitate advancement of the filter along the vessel's lumen. This requires less force to push the filter distally, enabling the mandrel to be smaller and reducing the outer diameter of the collapsed device, making

deployment in smaller vessels feasible. In addition, the reduced friction between the filter and the vessel wall limits damage to the intima of the vessel, permitting the filter to be deployed and moved with a minimum of trauma.

When the mandrel is retracted proximally, the stop 40 of the mandrel will
5 abut against, and exert a proximal biasing force on, the proximal slider 65 of the filter 50. This proximal biasing force will act against the restorative force of the body 52 to axially elongate and radially reduce that body. This permits the device to be withdrawn proximally along the lumen of the vessel either for repositioning at a more proximal location or for withdrawal from the patient's body at the end of the
10 procedure.

In the embodiment of Figures 1-3, the proximal and distal sliders 60, 65 are free to move relatively independently of one another, limited primarily by their indirect link to one another through the body 52 of the filter. For example, when the mandrel 20 is urged distally against the distal slider 60 (Figure 4), the proximal
15 slider will slide proximally along the proximal length 35 of the mandrel. Similarly, when the mandrel is withdrawn proximally to urge proximally against the proximal slider 65, the distal slider will be free to drift distally along the distal length 30 of the mandrel. Ideally, there should be a sufficient distance between the distal shoulder of the stop 40 and the proximal end of the helical coil 22 at the distal end
20 of the mandrel.

Figures 4-8 schematically depict one method of the invention utilizing an alternative filter design. Most of the elements of the filter 50' in Figures 4-8 are essentially the same as like elements in Figures 1-3, so the same reference numbers have been used for most elements in both sets of drawings. The
25 primary differences between the filter 50' of Figures 4-8 and the filter 50 described above is that the stop 40 has been omitted in Figures 4-8 and the proximal slider 65' has been secured to the mandrel 20 at a fixed location. The distal slider 60 remains free to slide along the mandrel.

The body 52' of the filter 50' is shaped a little differently from the filter body
30 52 of Figures 1-3. This difference is not crucial and does not yield significantly different properties. Instead, the differences in the fully deployed shapes of the

two filters 50, 50' are intended to highlight that the shape can vary without compromising the filter's function.

Figure 4 schematically illustrates the filter 50' collapsed within the lumen of a catheter C. The body 52' of the filter has been collapsed under the biasing force of the catheter walls into an axially elongated, radially reduced configuration. This catheter and filter combination may be advanced through a patient's body as a unit until a specific treatment site has been reached, but this combined unit may be difficult to steer through a more tortuous path. For many applications (e.g., deployment at a remote site within a patient's vasculature), the catheter will first be positioned adjacent the treatment site. Only then will the filter system be introduced into the distal end of the catheter C and urged along the catheter's lumen and the vessel V until the distal end 25 of the mandrel and the distal slider 65 are positioned adjacent the distal end of the catheter, as shown in Figure 4.

Regardless of how the system reaches the state illustrated in Figure 4, once the catheter is in place the filter 50' can be deployed out the distal end of the catheter. In particular, the filter 50' may be urged out of the distal end of the catheter, e.g., by holding the catheter C still and urging the mandrel 20 distally or by holding the mandrel 20 stationary and withdrawing the catheter C proximally.

Upon exiting the distal end of the catheter C, the flexible body 52 will resiliently expand radially outwardly, desirably until it engages the wall of the vessel V or, less desirably, is positioned adjacent to the vessel wall. (Such a configuration is shown in Figure 5.) This will help ensure that all fluid passing along the vessel V will have to pass through the filter body 52'.

A substantial portion (ideally, all or at least a vast majority) of the body fluid in the vessel should pass through the proximally oriented opening 56 in the filter body. Since the opening is fairly large, it is anticipated that any particulate material entrained in the body fluid travelling through the vessel will enter the interior of the filter through the opening 56. The pores in the distal length 53 of the filter body are significantly smaller, though, so most oversized particles will be trapped within the enclosure of the filter body. Figure 6 schematically depicts such a situation, with a number of individual particles P being shown trapped within the filter body. If the filter 50 or 50' is to be used in a vascular procedure,

the pores should be large enough to permit red blood cells to pass therethrough, but small enough to trap thrombi or emboli above a certain predetermined size.

A wide variety of vascular filters are known in the art and the ease with which such filters can be deployed varies. One of the primary distinguishing characteristics between these various filter designs is the ease with which the filters can be withdrawn from or repositioned within the patient's body. For example, most commercially available vena cava filters are provided with sharp barbs or other structures which firmly seat the devices in a wall of the vessel, but which effectively preclude retraction of the device. Temporary filters avoid such tenacious attachments to the vessel wall, permitting them to be retracted or moved after initial deployment. As noted above, though, one of the primary difficulties encountered in using such temporary filters is the risk of dumping the captured particulate material back into the vessel from which it was filtered. Many designs require that the physician first aspirate the particulate material or, in the case of thrombi captured in vascular procedures, use drugs which help break down the particles to clinically acceptable sizes.

International Publication No. WO 96/01591, mentioned previously, provides a particularly useful filter. This filter, which may be generally dome-shaped and have a proximally-facing lip, enables a physician to close the filter prior to retraction, keeping the captured particles within the filter during removal or repositioning. Unfortunately, this design is mechanically complex. In one embodiment disclosed therein, the filter is provided with a drawstring which can be used to draw the proximal edge of the filter down toward the wire on which it is carried, minimizing the risk of losing the particles. A second design proposed in this reference employs a separately deployable cover which can be brought into sealing engagement with the filter. While this may further reduce the risk of dumping particles back into the vessel, the increased mechanical complexity makes it difficult to provide a highly reliable, cost-effective device.

The present invention provides an elegant solution to these difficulties which minimizes mechanical complexity and promises to provide very effective containment of filtered particles. Figure 7 shows the filter 50' of Figures 4-6 partially retracted into the catheter C. If the filter is being used for only a short period of time, the catheter C may be the same catheter used to initially deploy

the filter in the vessel. If the filter is to be left in place for a longer period of time, though, it may be preferred to remove the deployment catheter (Figure 4) from the patient's body and later introduce a separate retrieval catheter by advancing the retrieval catheter along the mandrel 20.

5 The lumen of the retrieval catheter C in Figure 7 has a diameter smaller than the maximum cross-sectional dimension of the body's expanded configuration. The lumen is larger than the narrow proximal end of the filter body 52' adjacent the proximal slider 65', though, and the illustrated filter body is spaced from the vessel wall about its entire periphery. As a consequence, the
10 distal tip of the catheter can be positioned between the proximal end of the body 52' and the wall of the vessel V before the catheter engages the body of the filter adjacent the slider. This can be done by holding the catheter in place and withdrawing the mandrel proximally, by holding the mandrel stationary and moving the catheter distally, or moving both the catheter and the mandrel.

15 Once the proximal end of the body 52' is introduced into the catheter's lumen, the rest of the body can be drawn into the lumen of the catheter. Again, the body can be drawn into the catheter by advancing the catheter distally or retracing the filter proximally. At some point, the wall of the catheter C will engage the larger diameter body 52. Ideally, the lumen of the catheter is notably smaller
20 than the deployed diameter of the filter body. As shown in Figure 7, in this case the walls of the catheter will exert a biasing force to urge the body toward the radially reduced configuration in which it was initially deployed (Figure 4).

 Perhaps more importantly, though, the internal surface of the catheter engages the body of the filter distally of the filter's proximally oriented opening 56.
25 While the opening may still be open to the lumen of the catheter, the engagement between the filter body and the catheter wall distally of the opening effectively creates a particulate seal therebetween. As a consequence, simply by advancing the catheter C with respect to the filter 50', one can seal within the combined catheter and filter all of the captured particles above the predetermined minimum
30 size. This combination can then be moved as a unit either to remove it from or reposition it within the patient's body with minimal risk of losing any of the captured particles.

If the filter is to be completely withdrawn from the vessel, it is preferred that the filter body 52' be completely withdrawn into the lumen of the catheter (as shown in Figure 8) rather than leaving a distal section of the filter extending out of the catheter (as shown in Figure 7). This will reduce friction against the vessel wall, making withdrawal easier and reducing trauma to the intima of the vessel.

While a preferred embodiment of the present invention has been described, it should be understood that various changes, adaptations and modifications may be made therein without departing from the spirit of the invention and the scope of the appended claims.

WHAT IS CLAIMED IS:

1. A method of deploying a medical filter within a channel in a patient's body, the method comprising:
 - a) providing a filter having a radially expandable body having proximal and distal ends and defining an enclosure, the body having a distal length and a proximal length which has an opening therein; and a retrieval catheter having a lumen with a diameter less than a maximum dimension of the body's expanded configuration;
 - b) urging the filter along a length of the channel with the filter body in a radially reduced configuration;
 - c) radially expanding the body to its expanded configuration such that it substantially fills the lumen of the vessel and the opening in the body is oriented proximally;
 - d) permitting body fluid to enter the enclosure through the proximally oriented opening and pass distally through the distal length of the body, the distal length of the body filtering from the body fluid particulate material entrained therein; and
 - e) drawing the proximal length of the body within the lumen of the retrieval catheter, thereby effectively closing the proximally oriented opening within the catheter to retain said particulate material within the enclosure.
2. The method of claim 1 wherein the proximal length of the filter's body tapers proximally to a narrow proximal end which is smaller than the lumen of the catheter, the step of drawing the proximal length within the catheter comprising receiving a narrow proximal end of the body in the lumen of the catheter then retracting the filter until the internal surface of the catheter engages the body of the filter distally of the opening to effectively create a particulate seal therebetween.
3. The method of claim 2 wherein the narrow proximal end of the body is spaced from a wall of the vessel when the filter is expanded into its expanded configuration.

4. The method of claim 3 wherein a wall of the catheter is positioned between the narrow proximal end of the body and the wall of the vessel as the proximal length of the body is drawn into the lumen of the catheter.
5. The method of claim 1 wherein a wall of the catheter urges the filter's body radially inwardly toward said radially reduced configuration as the body is drawn into the lumen thereof.
6. The method of claim 1 wherein the filter is urged along the channel in said radially reduced configuration within a deployment catheter.
7. The method of claim 6 wherein the same catheter is used as both the deployment catheter and the retrieval catheter.
8. The method of claim 6 wherein the deployment catheter's wall constrains the filter body in said radially reduced configuration when the body is received in the lumen thereof, body being radially expanded by deploying the filter out of the distal end of the catheter, whereupon the body resiliently expands radially outwardly upon removal of the constraint.
9. The method of claim 1 wherein the retrieval catheter is held substantially stationary as the proximal length of the filter's body is drawn therewithin.
10. The method of claim 1 wherein the proximal length of the filter's body is drawn into the catheter's lumen by holding the body substantially stationary and advancing the catheter distally over the proximal length thereof.
11. The method of claim 1 wherein the filter is carried by a mandrel, the catheter being advanced along the mandrel prior to drawing the body of the filter into the lumen thereof.
12. A collapsible filter system comprising:
 - a) a mandrel having a distal end and a proximal end; and
 - b) a filter carried along the mandrel, the filter comprising a radially expandable body having a proximal end and a distal end, the body being formed of a porous, resilient fabric having pores therein through which a body fluid may pass, but which restrict passage therethrough of particulate material entrained in the body fluid;
 - c) a proximally oriented hole passing through the fabric along a proximal length of the filter's body, the hole being spaced distally of

the proximal end of the body and being at least about ten times the size of said pores.

13. The medical filter of claim 12 wherein the proximal length of the body tapers toward the body's proximal end.
- 5 14. The medical filter of claim 12 wherein one of the proximal end and the distal end of the body is secured to the mandrel at a fixed location therealong while the other end of the body is slidably carried by the mandrel.
- 10 15. The medical filter of claim 12 wherein the proximal end of the body is secured to the mandrel at a fixed location therealong while the distal end of the body is slidably carried by the mandrel.
- 15 16. The medical filter of claim 12 wherein the mandrel includes a stop spaced proximally of its distal end and positioned between the proximal and distal ends of the body, a proximal length of the mandrel extending proximally of the stop and a distal length of the mandrel extending distally of the stop.
- 20 17. The medical filter of claim 16 wherein the proximal end of the body is slidably carried along the proximal length of the mandrel and the distal end of the body is slidably carried along the distal length of the mandrel, the proximal and distal ends being slidable along the mandrel independently of one another such that the distance between the proximal and distal ends can be varied to effect different configurations of the filter.
18. The medical filter of claim 12 wherein the proximal end of the body is affixed to the mandrel adjacent a distal end thereof.
- 25 19. The medical filter of claim 12 wherein the proximal length of the filter's body includes a plurality of proximally oriented holes through the fabric.
20. The medical filter of claim 12 wherein the filter body defines an enclosure for retaining particulate material therein, the mandrel extending through the enclosure.
- 30 21. The medical filter of claim 20 wherein the enclosure has a central axis, the mandrel being spaced radially outward from the central axis and extending closer to one side of the body than to an opposite side of the body.
22. A method of using the medical filter of claim 12 wherein the radially expandable body is placed in a radially reduced configuration for

deployment; the body is radially expanded to an expanded configuration at a treatment site; and a retrieval sheath is urged distally with respect to the filter, the retrieval sheath receiving therewithin the proximal length of the filter's body while engaging a periphery of the body distally of the opening, thereby effectively closing the proximally oriented opening within the retrieval sheath.

THIS PAGE BLANK (USPTO)

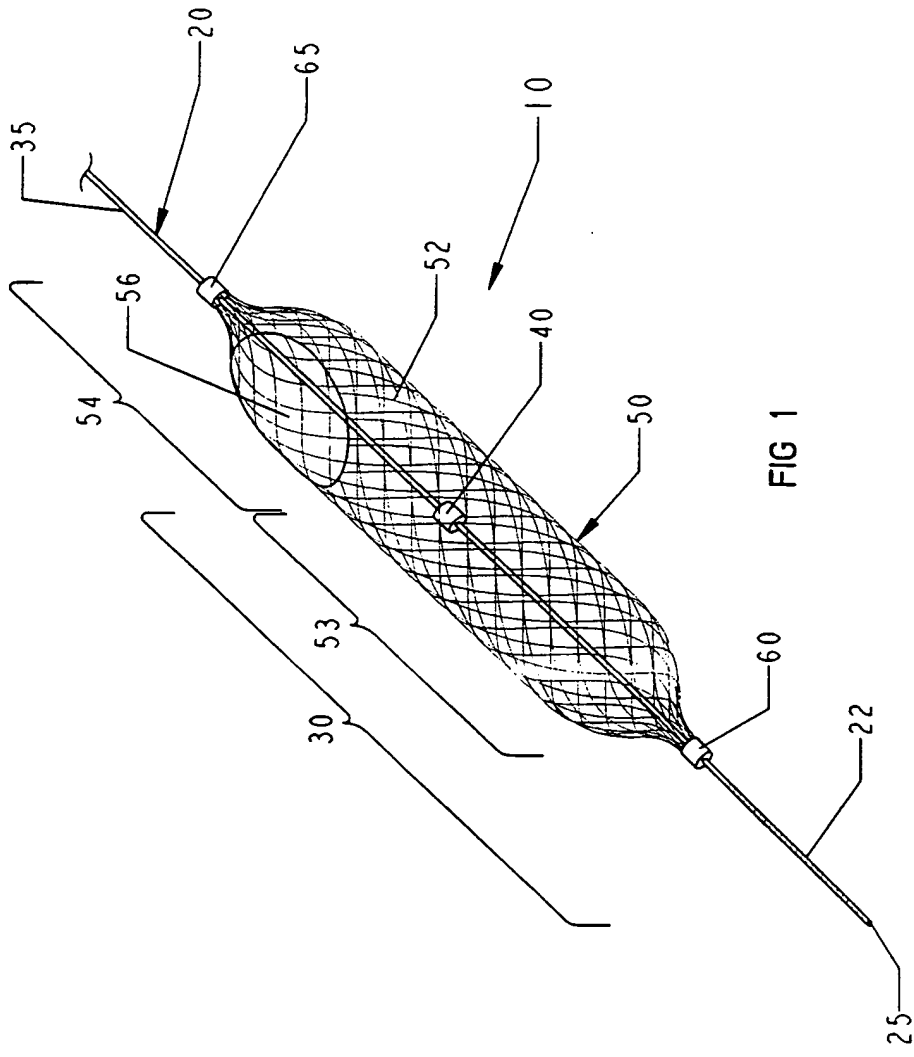

FIG 1

THIS PAGE BLANK (USPTO)

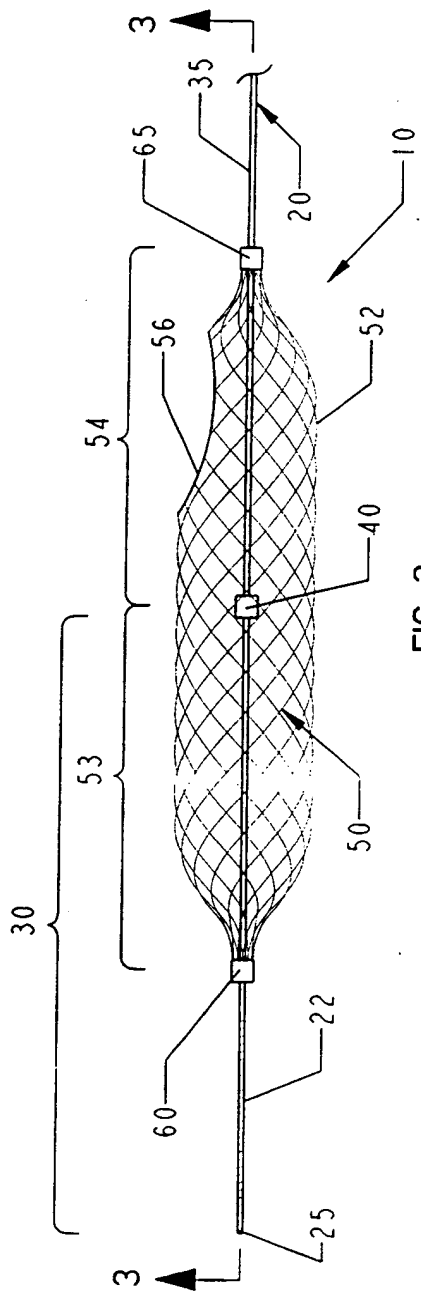

FIG 2

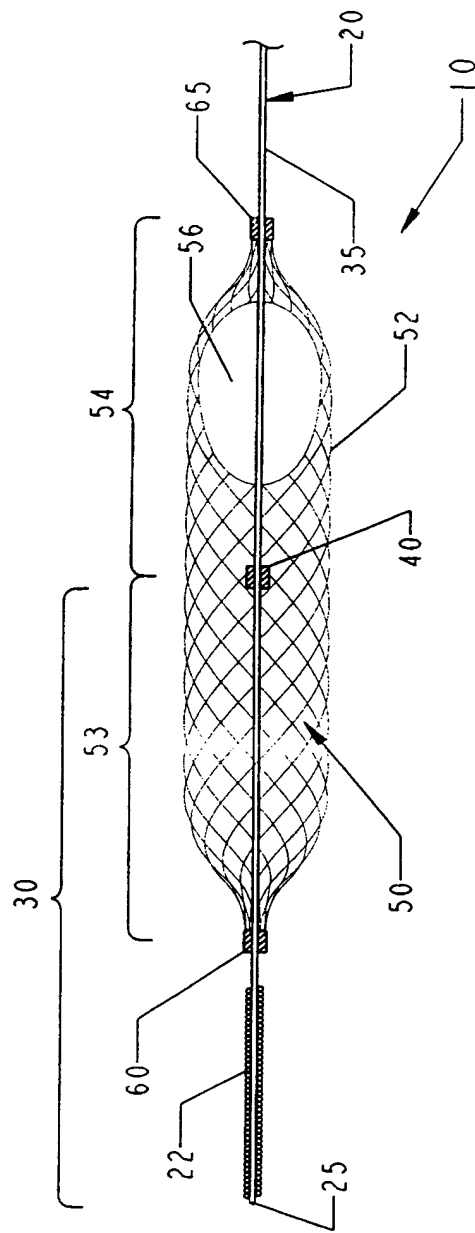

FIG 3

THIS PAGE BLANK (USPTO)

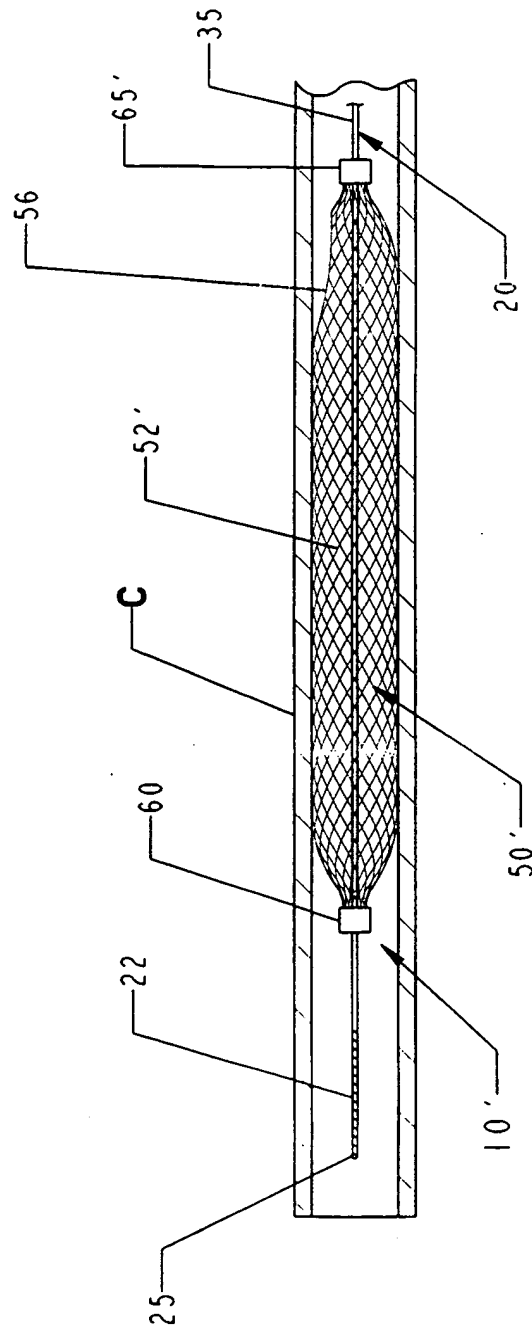

FIG 4

THIS PAGE BLANK (USPTO)

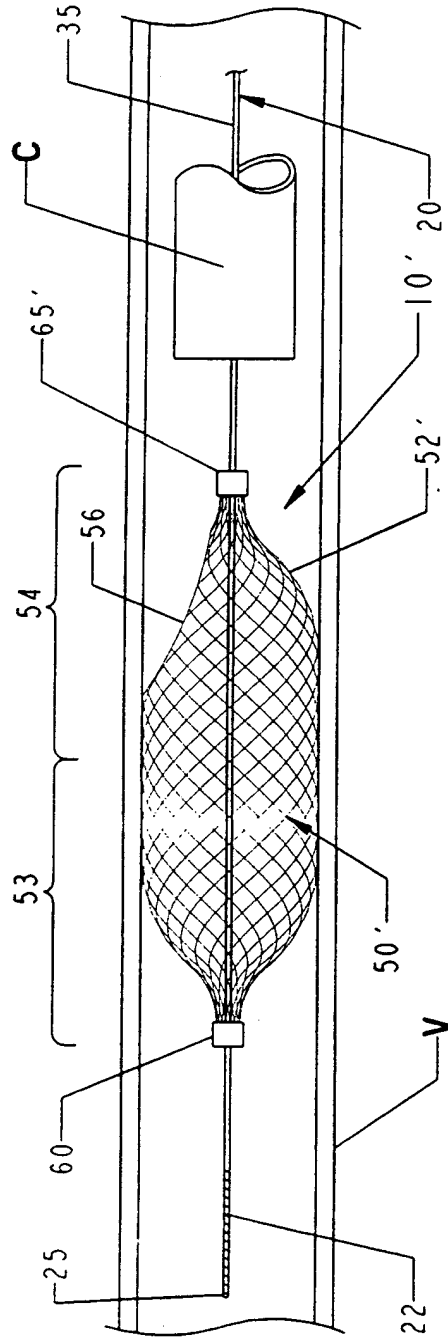

FIG 5

THIS PAGE BLANK (USPTO)

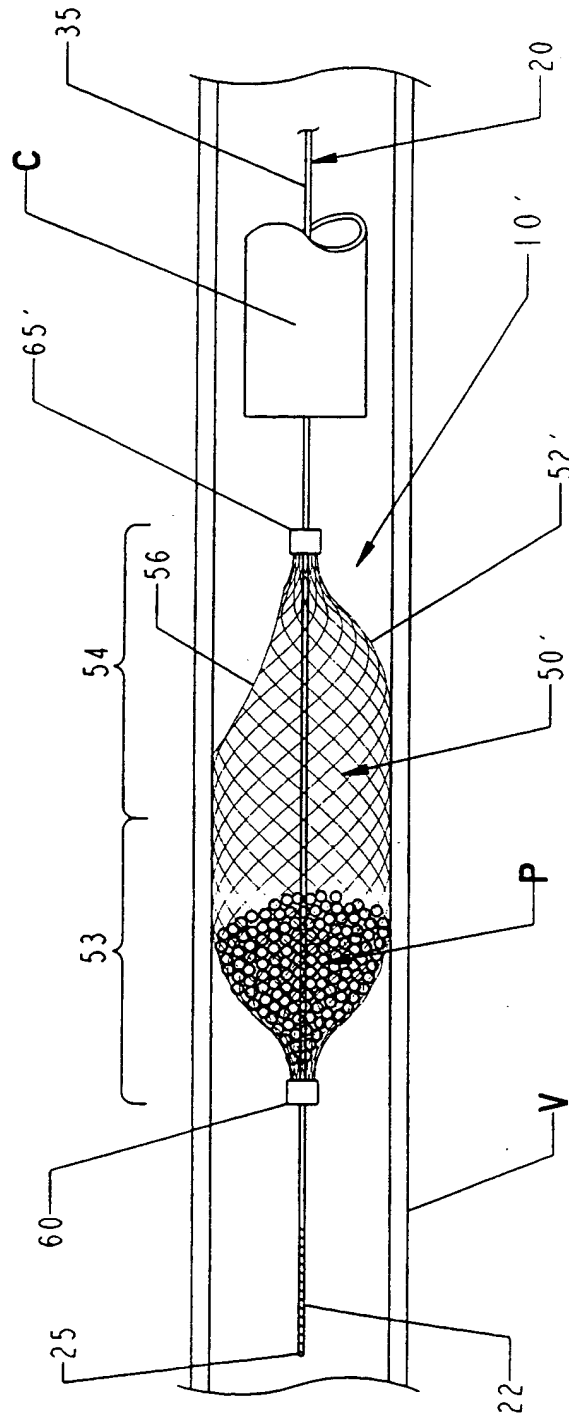

FIG 6

THIS PAGE BLANK (USPTO)

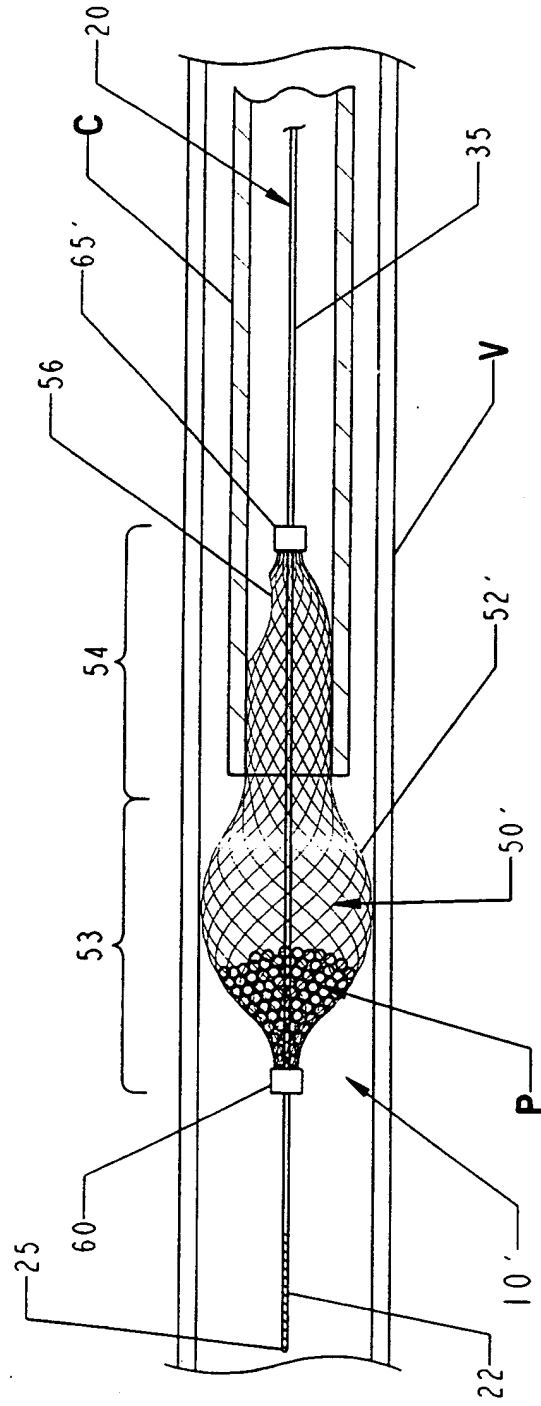

FIG 7

THIS PAGE BLANK (USPTO)

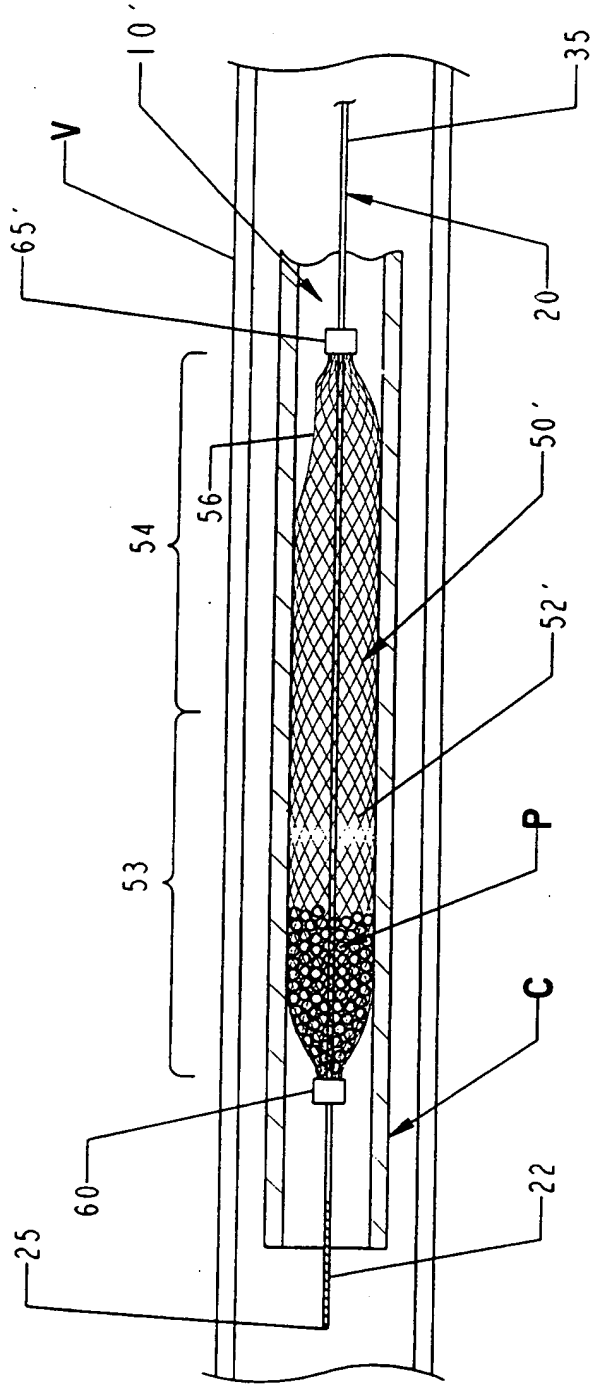

FIG 8

THIS PAGE BLANK (USPTO)

INTERNATIONAL SEARCH REPORT

International Application No
PCT/US 00/25049

A. CLASSIFICATION OF SUBJECT MATTER IPC 7 A61F2/01 A61B17/22		
According to International Patent Classification (IPC) or to both national classification and IPC		
B. FIELDS SEARCHED		
Minimum documentation searched (classification system followed by classification symbols) IPC 7 A61F A61B		
Documentation searched other than minimum documentation to the extent that such documents are included in the fields searched		
Electronic data base consulted during the international search (name of data base and, where practical, search terms used) EPO-Internal		
C. DOCUMENTS CONSIDERED TO BE RELEVANT		
Category *	Citation of document, with indication, where appropriate, of the relevant passages	Relevant to claim No.
X	WO 99 23976 A (TAYLOR CHARLES ;BRADY EAMON (IE); GILSON PAUL (IE); MAHER PADRAIG) 20 May 1999 (1999-05-20) page 21, line 5 - line 10; figures ---	12-21
A	EP 0 820 729 A (TARGET THERAPEUTICS INC) 28 January 1998 (1998-01-28) column 9, line 53 -column 11, line 25; figures 5-8,11-16 ---	12-14, 19,20
A	US 5 814 064 A (DANIEL JOHN M K ET AL) 29 September 1998 (1998-09-29) column 8, line 27 - line 65; figures 14A-C ---	12,13, 19,20
<input type="checkbox"/> Further documents are listed in the continuation of box C.		
<input checked="" type="checkbox"/> Patent family members are listed in annex.		
* Special categories of cited documents :		
A document defining the general state of the art which is not considered to be of particular relevance *E* earlier document but published on or after the international filing date *L* document which may throw doubts on priority claim(s) or which is cited to establish the publication date of another citation or other special reason (as specified) *O* document referring to an oral disclosure, use, exhibition or other means *P* document published prior to the international filing date but later than the priority date claimed *T* later document published after the international filing date or priority date and not in conflict with the application but cited to understand the principle or theory underlying the invention *X* document of particular relevance; the claimed invention cannot be considered novel or cannot be considered to involve an inventive step when the document is taken alone *Y* document of particular relevance; the claimed invention cannot be considered to involve an inventive step when the document is combined with one or more other such documents, such combination being obvious to a person skilled in the art. *Z* document member of the same patent family		
Date of the actual completion of the international search	Date of mailing of the international search report	
6 December 2000	13/12/2000	
Name and mailing address of the ISA European Patent Office, P.B. 5818 Patentlaan 2 NL - 2280 HV Rijswijk Tel. (+31-70) 340-2040, Tx. 31 651 epo nl. Fax: (+31-70) 340-3016	Authorized officer Neumann, E	

INTERNATIONAL SEARCH REPORT

Information on patent family members

International Application No

PCT/US 00/25049

Patent document cited in search report	Publication date	Patent family member(s)	Publication date
WO 9923976 A	20-05-1999	AU 9758398 A	31-05-1999
		BR 9813935 A	19-09-2000
		DE 19882777 T	26-10-2000
		EP 1028670 A	23-08-2000
		GB 2345253 A	05-07-2000
		IE 81060 B	12-01-2000
		NO 20002303 A	04-05-2000
		EP 0820729 A	28-01-1998
US 5972019 A	26-10-1999		
AU 3081897 A	05-02-1998		
CA 2211516 A	25-01-1998		
EP 0914807 A	12-05-1999		
JP 10151136 A	09-06-1998		
NO 973428 A	26-01-1998		
US 5814064 A	29-09-1998	EP 0923344 A	23-06-1999
		US 6053932 A	25-04-2000
		WO 9838920 A	11-09-1998
		US 6001118 A	14-12-1999